

**ALTERNATORE SERIE T20F - ELENCO PARTI DI RICAMBIO / ALTERNATOR SERIES T20F - LIST OF SPARE PARTS  
ALTERNATEUR SERIE T20F - LISTE DES PIECES DETACHEES / GENERATOR SERIE T20F-ERSATZTEILLISTE  
ALTERNADOR SERIE T20F - LISTA PARTES DE REPUESTO**

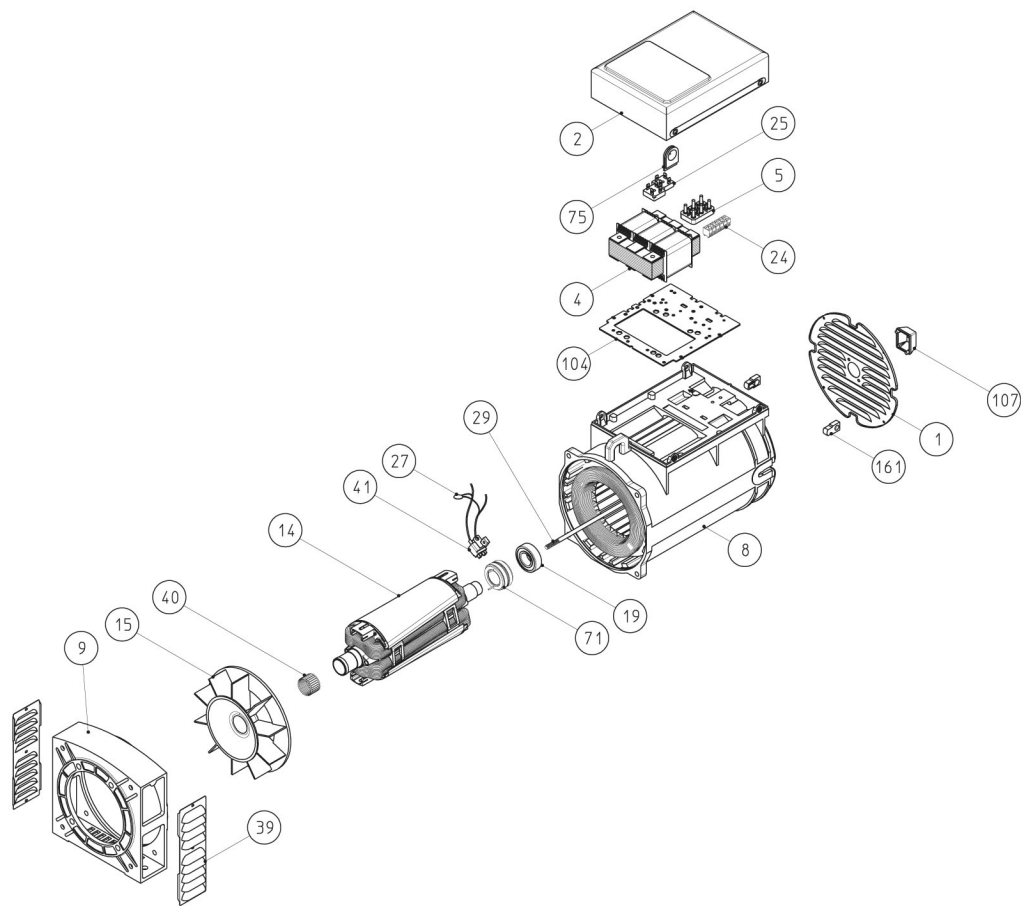

N.	DENOMINAZIONE	NAME	DESIGNATION	NAMEN	DENOMINACION	CODICE-CODE
1	CHIUSURA POSTERIORE	REAR SEAL	TOLE DE FERMETURE ARRIERE	HINTERER DECKEL	CIERRE POSTERIOR	0390700011
2	CUFFIA	TERMINAL BOX LID	COUVERCLE	DECKEL	TAPA	0390501015
4	TRASFORMATORE	REGULATING TRANSFORMER	TRANSFORMATEUR	TRANSFORMATOR	TRANSFORMADOR	-
5	MORSETTIERA UTILIZZAZIONE 56x36	TERMINAL BOARD 56x36	PLANCHETTE A' BORNES 56x36	KLEMMBRETT	PLACA DE BORNES	9909915060
8	CARCASSA CON STATORE	FRAME AND STATOR	CARCASSE AVEC STATOR	GEHÄUSE MIT STATOR	CARCASA CON ESTATOR	-
9	COPERCHIO FORMA MD35	DRIVE END BRACKET MD35	FLASQUE MD35	FLANSCH MD35	BRIDA MD35	-
	COPERCHIO FORMA B9	DRIVE END BRACKET B9	FLASQUE B9	FLANSCH B9	BRIDA B9	-
	COPERCHIO FORMA B14	DRIVE END BRACKET B14	FLASQUE B14	FLANSCH B14	BRIDA B14	0391700143
14	INDUTTORE ROTANTE	ROTOR ASSY	INDUCTEUR TOURNANT	ROTIERENDER INDUKTOR	INDUCTOR ROTANTE	-
15	VENTOLA	FAN	VENTILATEUR	LÜFTER	VENTILADOR	0392000033
17	CUSCINETTO ANTERIORE 6306-2RS	FRONT BEARING 6306-2RS	ROULEMENT AVANT 6306-2RS	VORDERES LAGER 6306-2RS	COJINETE DELANTERO 6306-2RS	0390302532
19	CUSCINETTO POSTERIORE 6205-2RS	REAR BEARING 6205-2RS	ROULEMENT ARRIERE 6205-2RS	HINTERES LAGER 6205-2RS	COJINETE POSTERIOR 6205-2RS	0390302511
24	MORSETTIERA AUSILIARIA	AUXILIARY TERMINAL BOARD	BORNES AUXILIAIRES	NEBEN-KLEMMBRETT	REGLETA	0391100110
25	PONTE RADDRIZZANTE MONOFASE SKB25-08	RECTIFYNG 1 PHASE BRIDGE SKB25-08	PONT REDRESSEUR MONOPHASE SKB25-08	EINPHASIGE RICHTBRÜCKE SKB25-08	PUENTE RECTIFICADOR SKB25-08	9910390115
27	VARISTORE	VARISTOR	VARISTOR	VARISTOR	VARISTOR	9910384005
29	TIRANTE CENTRALE	SECURING STUD	TIGE CENTRALE	ZENTRIERSSTIFT	TIRANTE CENTRAL	-
39	RETINA DI PROTEZIONE	PROTECTION SCREEN	GRILLE DE PROTECTION	SCHÜTZGITTER	REJILLA DE PROTECCION	-
40	ANELLO COMPENSATORE (MOD. BN 35x23)	FIXING RING (MOD. BN 35x23)	RONDELLE DE BLOUAGEMOD. BN 35x23)	KOMPENSATOR RING (MOD. BN 35x23)	ANILLO COMPENSADORES (MOD. BN 35x23)	0390100211
41	GRUPPO SPAZZOLE COMPLETO BH 40	BRUSH GEAR ASSEMBLY BH 40	ENSEMBLE PORTE BALAIS COMPLET BH 40	BÜRSTERNHALTER BH 40	PORTAESCOBILLAS BH 40	0390700064
71	COLLETTORE AD ANELLI	SLIP RING	BAGUES	BÜRSTENRING	COLECTOR DE ANILLOS	0390302348
75	GOMMINO PASSACAVO	RUBBER GROMMET	PASSE-CABLES EN CAOUTCHOUC	GUMMI AUGE	GOMA PASACABLES	9909509081
104	PANNELLO PORTA-COMPONENTI	COMPONENT HOLDING PANEL	PANNEAU PORTE COMPOSANTS	KOMPONENTENBLECHTAFEL	TABLERO PORTA COMPONENTES	0390302841
107	TAPPO PER CUFFIA POSTERIORE	SECURING STUD CUP	BOUCHON POUR CAPOT ARRIERE	STÖPSEL FÜR HINTERES KLEMMKASTENDECKEL	GOMA PARA TAPA POSTERIOR	9909505006
161	GOMMINO	RUBBER-CUP	CAPOUCHON DE FERMETURE EN PLASTIQUE	SCHLUSSGUMMI	GOMA DE CIERRE	0390700306

N.B.- Nella richiesta di pezzi di ricambio specificare il tipo e il codice dell'alternatore.

When requesting spare parts always indicate the alternator's type and code.

Pour toute demande de pièces détachées, prière de mentionner le type et le code de l'alternateur.

Bei Ersatzteilbestellung bitte immer die Teilbenennung den Typ und den code des Wechselstromgenerators angeben.

En cada pedido de piezas de recambio especificar siempre el tipo y el código del alternador.