

KIPOR

KIPOR POWER

OPERATION MANUAL

PLEASE READ THIS MANUAL CAREFULLY.
IT CONTAINS IMPORTANT SAFETY INFORMATION.

WWW.KIPOR.COM

KIPOR

WUXI KIPOR POWER CO., LTD.

Address: Beside Jingyi Rd, Third-stage Development Section
of Wangzhuang Industry Area, Wuxi High &
New Technology Industry Development Zone.

TEL: 0086-510-85200888

FAX: 0086-510-85200999

E-MAIL: kipor@kipor.com

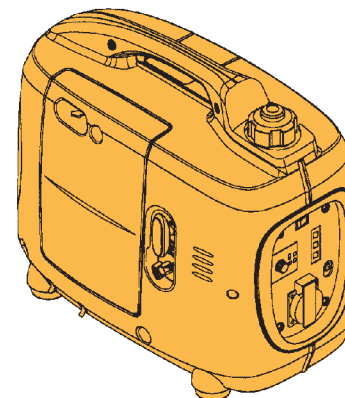

SINEMASTER

DIGITAL INVERTER GENERATOR

IG1000

IG1000s

Version 4, Printing date 04/08/2006

PREFACE

Thank you for purchasing our generators.

This manual covers operation and maintenance of the IG1000, IG1000s generator.

All information in this publication is based on the latest product information available at the time of approval for printing.

We reserve the right to make changes at any time without notice and without incurring any obligation.

No part of this publication may be reproduced without written permission.

This manual should be considered a permanent part of the generator and should remain with it if it is resold.

Pay special attention to statements preceded by the following words;



Failure to properly follow these precautions can result in property damage, serious injury or DEATH!

Read all labels and the owner's manual before operating this generator.

Operate only in well ventilated areas. Exhaust gas contains poisonous carbon monoxide, and can be deadly. Always stop engine before refueling. Wait 5 minutes before restarting.

Check for spilled fuel or leaks. Clean and/or repair before use.

Keep any sources of ignition away from fuel tank, at all times.



Indicates a strong possibility of severe personal injury or death if instructions are not followed.



Indicates a possibility of personal injury or equipment damage if instructions are not followed.

NOTE: Gives helpful information.

If a problem should arise, or if you have any questions about the generator, consult an authorized dealer.



Our generators are designed to give safe and dependable service if operated according to instructions. Read and understand the Owner's Manual before operating the generator. Failure to do so could result in personal injury or equipment damage.

■ The illustration may vary according to the type.

12. LIGHT KIT

MOUNTING INSTRUCTIONS FOR: IG1000s LIGHT KIT

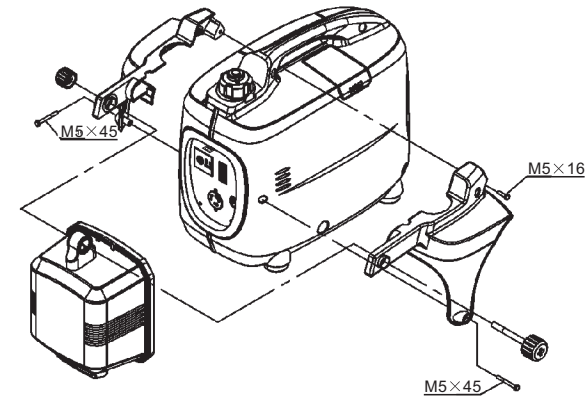

Our IG1000S Light kit is designed specifically for use on IG1000 Generator.

Tools required: Phillips Screwdriver

Fittings supplied:

- (1) IG1000 Portable Digital Generator
- (2) IG1000s-05100 Light Kit Assembly
- (3) IG1000s-05001 Antiskid Round Nut
- (4) IG1000s-05001 Antiskid Round Stud
- (5) IG1000s-05003 Left Mount Plate of Light Kit
- (6) IG1000s-05004 Right Mount Plate of Light Kit
- (7) Screw M5×45 2PCS
- (8) Screw M5×16 1PCS

This is where the Light Kit will be mounted, see IG1000s assembly Drawing of the Portable Digital Generator Light Kit.

- (1) Remove the screw from the IG1000 Portable Digital Generator and the screws from the side of the control plate;
- (2) Disperse the mount plate of the Light, use screw M5×45 and screw M5×16, then locate the mount plate of Light Kit on generator. DO NOT TIGHTEN SCREWS.
- (3) Use the antiskid round stud through the Light \ left and right mount plate in turn, then lock the antiskid round stud.
- (4) After adjusting the turnover angular of Light, tighten the above mentioned of antiskid round stud, screw M5×45 and screw M5×16 in turn.

Before energizing the light, be sure to read the Generator Owner's Manual for best operation and maintenance information, along with the safety precautions. It is recommended that the light switch be in the OFF position when starting the generator.

11. SPECIFICATIONS

SPECIFICATIONS

Model	IG1000 / IG1000s		
	Rated frequency (Hz)	50	60
Rated voltage (V)	230	120	240
Rated current (A)	3.9	7.5	3.8
Rated speed (rpm)	5500		
Rated output (kVA)	0.9		
Max output (kVA)	1.0		

DC output

DC voltage	12V-8.3A
Electric circuit breaker	Without
Phase number	Single phase

Engine

Model Type	KG55
Type	Single cylinder, 4 stroke, vertical, air-cooled, OHV, gasoline engine
Displacement (Bore×Stroke)	53.5ml (43.5×36mm)
Compression ratio	8.5:1
Rated power [kW(Hp)/(r/min)]	1.3/5500
Ignition system	T. C. I
Spark plug	A7RTC
Starting system	Electric starter
Fuel	Automotive unleaded gasoline
Fuel consumption (g/kW.h)	420
Lube oil	SAE 10W30 (above CC grade)

Fuel tank capacity (L)	2.6
Continuous running time (hr) (at rated output)	5.0
Noise level(zero load~ full load) [dB(A)/7m]	54-59 *
Overall dimension (L×W×H) [mm(in)]	IG1000: 460×248×395 (18.11×9.76×15.55) IG1000s: 605×250×400 (23.82×9.84×15.75)
Dry weight [kg(lbs)]	IG1000: 14 (30.8) IG1000s: 15.5 (34.1)

*: The declared values shall consider uncertainties due to production variation and measurement procedures.

CONTENTS

1. Safety Instructions	1
2. Safety Label Locations	3
3. Component Identification	4
4. Pre-operation Check	7
5. Starting the Engine	10
High altitude operation	12
6. Generator Use	13
7. Stopping the Engine	21
8. Maintenance	23
9. Transporting/Storage	30
10. Troubleshooting	32
11. Specifications	34
12. Light Kit	35

Appliance does not operate:

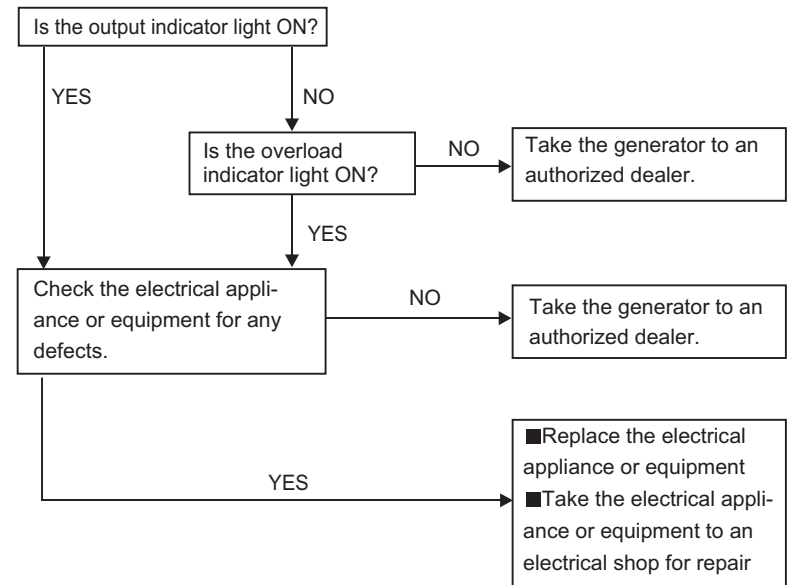

No electricity at the DC receptacle:

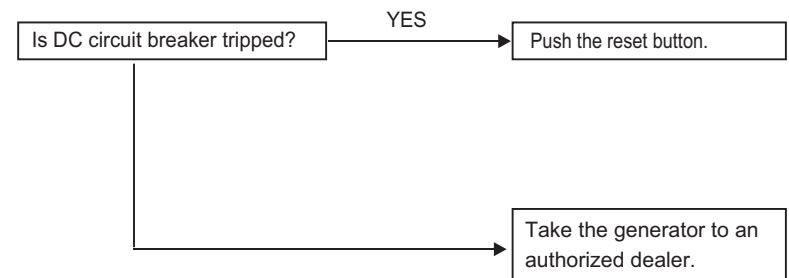

10. TROUBLESHOOTING

When the engine will not start:

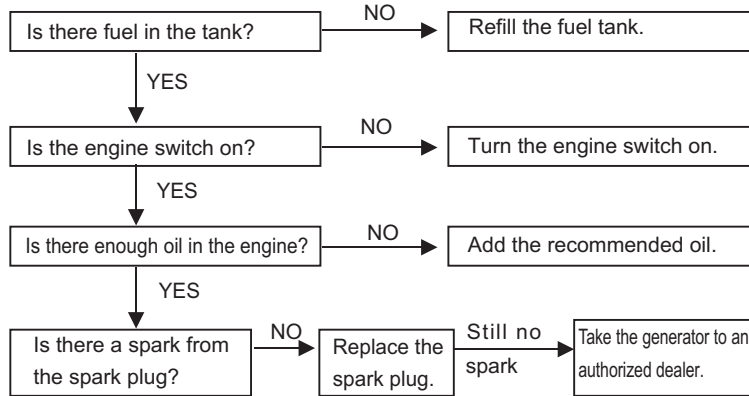

WARNING

- Be sure there is no spilled fuel around the spark plug. Spilled fuel may ignite.

If the engine still does not start, take the generator to an authorized dealer.

To check:

- Remove the spark plug cap and clean any dirt from around the spark plug.
- Remove the spark plug and install the spark plug in the plug cap.
- Set the plug side electrode on the cylinder head to ground.
- Pull the recoil starter, sparks should jump across the gap.

1. SAFETY INSTRUCTIONS

WARNING



- Our generators are designed to give safe and dependable service if operated according to instructions. Read and understand the Owner's Manual before operating the generator. Failure to do so could result in personal injury or equipment damage.

WARNING



- Exhaust gas contains poisonous carbon monoxide. Never run the generator in an enclosed area. Be sure to provide adequate ventilation. When installed in ventilated protection are to be observed.

WARNING



- The muffler becomes very hot during operation and remains hot for a while after stopping the engine. Be careful not to touch the muffler while it is hot. Let the engine cool before storing the generator indoors. The engine exhaust system will be heated during operation and remain hot immediately after stopping the engine. To prevent scalding, pay attention to the warning marks attached to the generator.

To ensure safe operation--



- Gasoline is extremely flammable and explosive under certain conditions. Refuel in a well ventilated area with the engine stopped.
- Keep away from cigarette, smoke and sparks when refueling the generator. Always refuel in a well-ventilated location.
- Wipe up spilled gasoline at once.



- Connections for standby power to a building's electrical system must be made by a qualified electrician and must comply with all applicable laws and electrical codes. Improper connections can allow electrical current from the generator to back feed into the utility lines. Such back feed may electrocute utility company workers or others who contact the lines during a power outage, and when utility power is restored, the generator may explode, burn, or cause fires in the building's electrical system.



- Always make a pre-operation inspection before you start the engine. You may prevent an accident or equipment damage.
- Place the generator at least 1m(3ft) away from buildings or other equipment during operation.
- Operate the generator on a level surface.
If the generator is tilted, fuel spillage may result.
- Know how to stop the generator quickly and understand operation of all the controls. Never permit anyone to operate the generator without proper instructions.
- Keep children and pets away from the generator when it is in operation.
- Keep away from rotating parts while the generator is running.
- The generator is a potential source of electrical shocks when misused; do not operate with wet hands.
- Do not operate the generator in rain or snow and do not let it get wet.

- Drain all gasoline from the fuel tank into an approved gasoline container.
- Turn the engine switch ON, and loosen the carburetor drain screw and drain the gasoline from the carburetor into a suitable container.
- With the drain screw loosened remove the spark plug cap, and pull the starter grip 3 to 4 times to drain the gasoline from the fuel pump.
- Turn the engine switch to the OFF position, and tighten the drain screw securely.

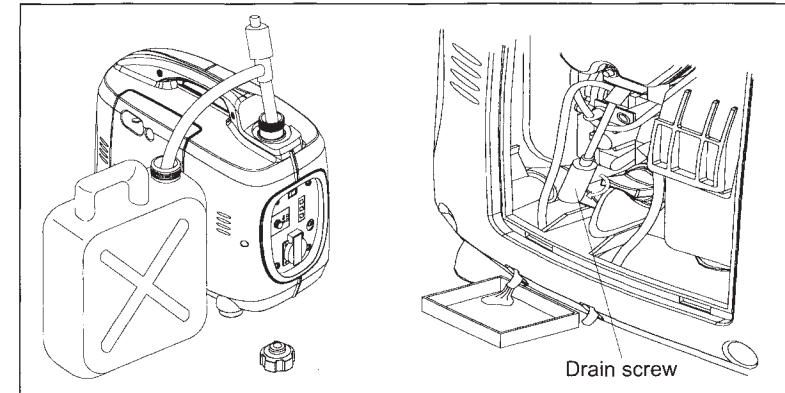

3. Change the engine oil.
4. Remove the spark plug and pour about a tablespoon of clean engine oil into the cylinder.
Crank the engine several revolutions to distribute the oil, then reinstall the spark plug.
5. Slowly pull the starter grip until resistance is felt. At this point, the piston is coming up on its compression stroke and both the intake and exhaust valves are

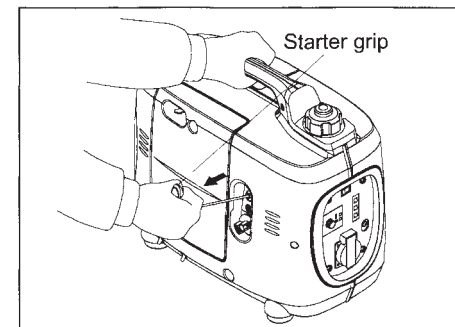

9. TRANSPORTING/STORAGE

To prevent fuel spillage when transporting or during temporary storage, the generator should be secured upright in its normal operating position, with the engine switch OFF. Turn the cap lever fully counterclockwise to the "OFF" position.

WARNING

- When transporting the generator.
- Do not overfill the tank (there should be no fuel in the filler neck)
- Do not operate the generator while it is on a vehicle.
Take the generator off the vehicle and use it in a well ventilated place.
- Avoid a place exposed to direct sunlight when putting the generator on a vehicle. If the generator is left in an enclosed vehicle for many hours, high temperature inside the vehicle could cause fuel to vaporize resulting in a possible explosion.
- Do not drive on a rough road for an extended period with the generator on board, if you must transport the generator on a rough road, drain the fuel from the generator beforehand.

Before storing the unit for an extended period:

1. Be sure the storage area is free of excessive humidity and dust.
2. Drain out the fuel completely.

WARNING

- Gasoline is extremely flammable and explosive under certain conditions.
Do not smoke or allow flames or sparks in the area.

2. SAFETY LABEL LOCATIONS

These labels warn you of potential hazards that can cause serious injury. Read the labels and safety notes and precautions described in this manual carefully. If a label comes off or becomes hard to read, contact your dealer for a replacement.

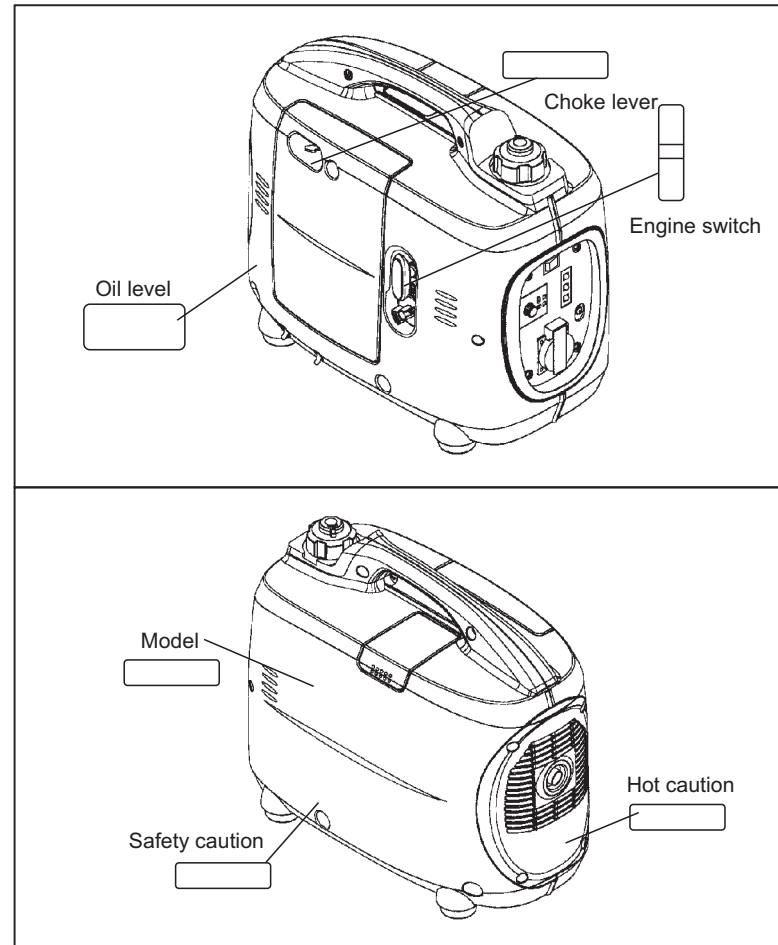

3.COMPONENT IDENTIFICATION

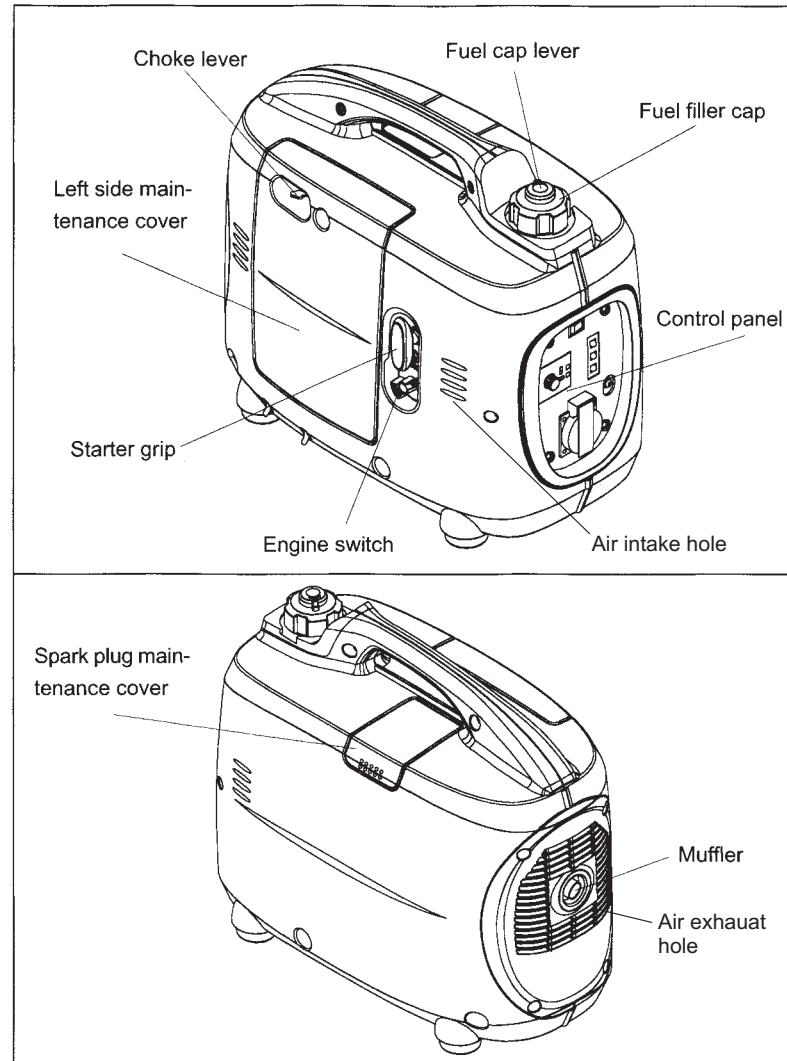

3. Use a brush to remove carbon deposits from the spark arrester screen. Inspect the screen for holes, and replace it if necessary.

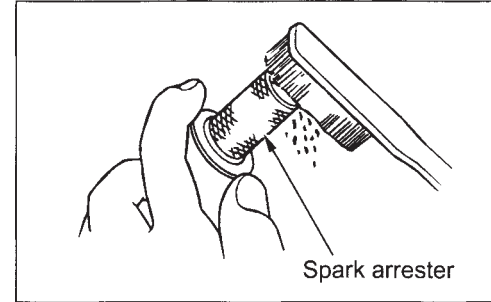

4. Check the muffler gasket; replace if damaged. Reinstall the muffler gasket, the spark arrester, the muffler and the muffler protector in the reverse order of removal.

4.SPARK ARRESTER MAINTENANCE(Equipped type only)

⚠ WARNING ■ If the generator has been running, the muffler will be very hot. Allow it to cool before proceeding.

⚠ CAUTION ■ The spark arrester must be serviced every 100 hours to maintain its efficiency.

1.Remove the four 5 mm screws, and remove the muffler protector.

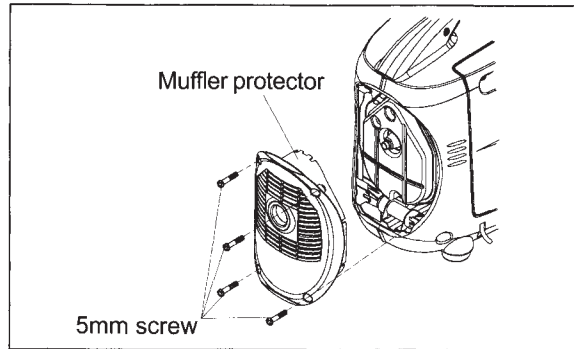

2.Remove the there 6 mm bolts, and remove the muffler, the spark arrester and the muffler gasket

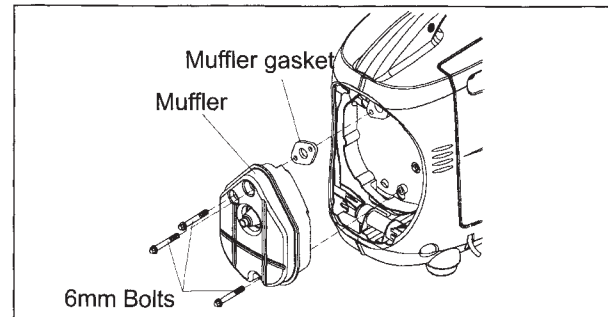

Control panel

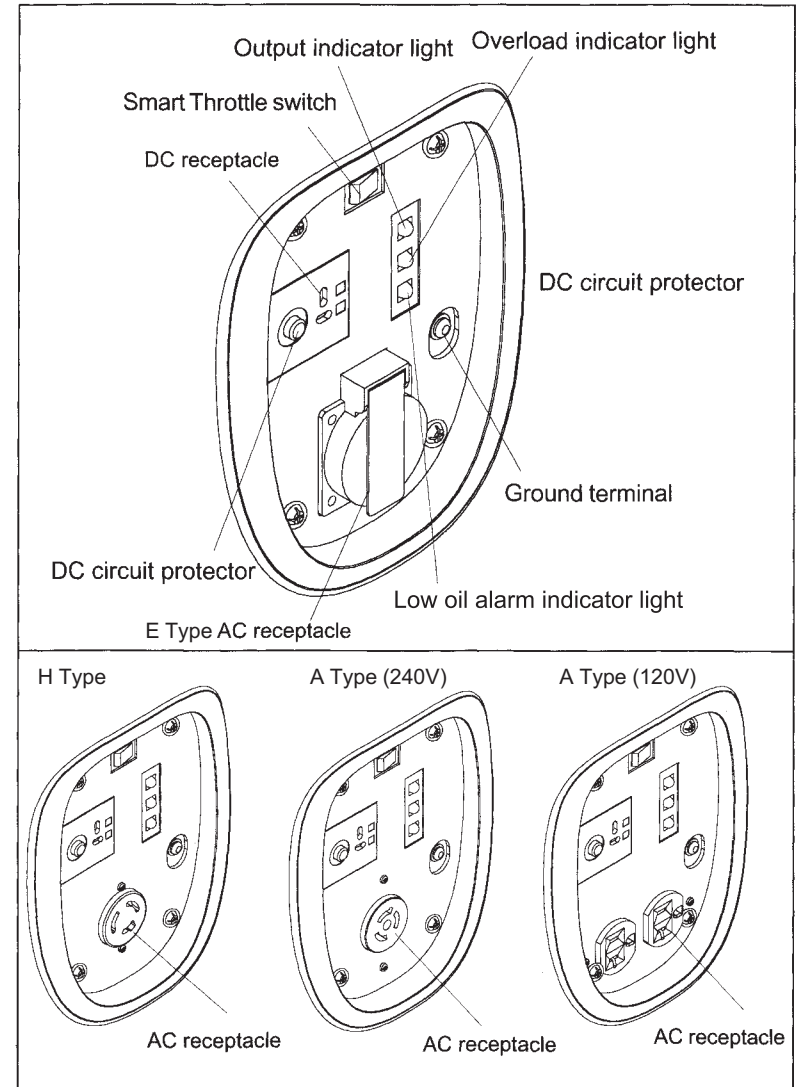

SMART throttle

Engine speed is kept at idle automatically when the electrical appliance is disconnected and it returns to the proper speed to power of the electrical load when electrical appliance is connected. This position is recommended to minimize the fuel consumption while in operation.

NOTE

- Smart throttle system does not operate effectively if the electrical appliance requires the momentary electric power.
- When high electrical loads are connected simultaneously turn the smart throttle switch to the OFF position to reduce voltage changes.
- In DC operation, turn the smart throttle switch to the OFF position.

OFF:

Note: Smart throttle system does not operate. Engine speed is kept over rated speed.

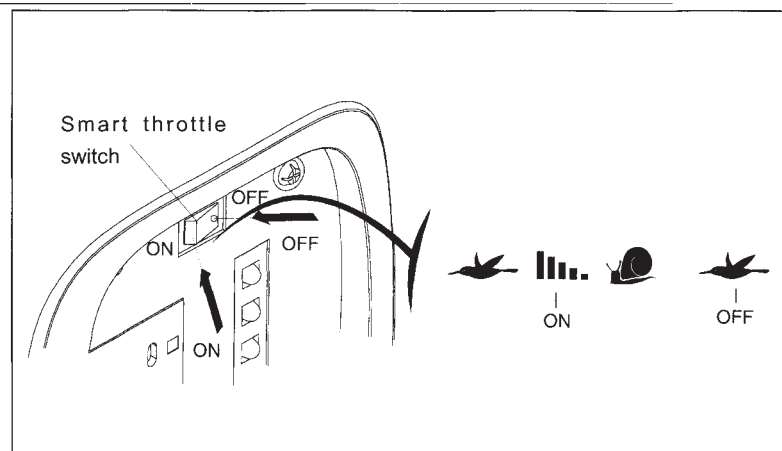

5. Visually inspect the spark plug. Discard it if the insulator is cracked or chipped. Clean the spark plug with a wire brush if it is to be reused.
6. Measure the plug gap with a feeler gauge. The gap should be 0.6-0.7mm (0.024-0.028in). Correct as necessary by carefully bending the side electrode.

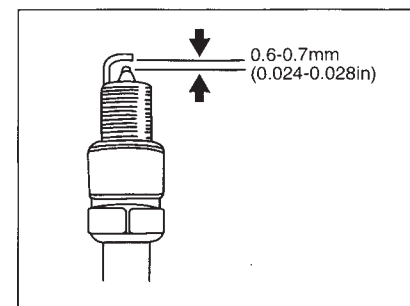

7. Install the spark plug carefully, by hand, to avoid cross-threading.
8. After a new spark plug has been seated by hand, it should be tightened 1/2 turn with a wrench to compress its washer. If a used plug is being reinstalled, it should only require 1/8 to 1/4 turn after being seated.
9. Reinstall the spark plug cap on the spark plug securely.
10. Reinstall the spark plug maintenance cover.

CAUTION

- The spark plug must be securely tightened. An improperly tightened plug can become very hot and possibly damage the generator.
- Never use a spark plug with an improper heat range.
- Never use a spark plug without damping resistance, or it will cause no AC output.

3.SPARK PLUG SERVICE

RECOMMENDED SPARK PLUG: A7RTC

To ensure proper engine operation, the spark plug must be properly gapped and free of deposits.

1.Remove the spark plug maintenance cover.

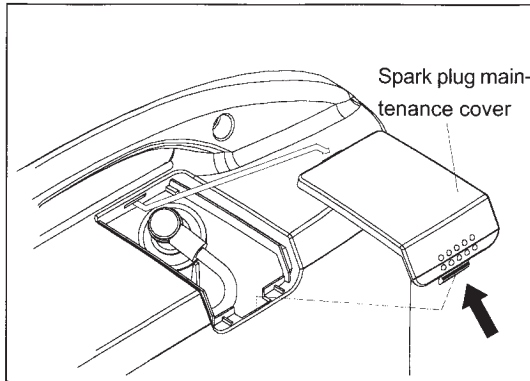

2.Remove the spark plug cap.

3.Clean any dirt from around the spark plug base.

4.Use the wrench to remove the spark plug.

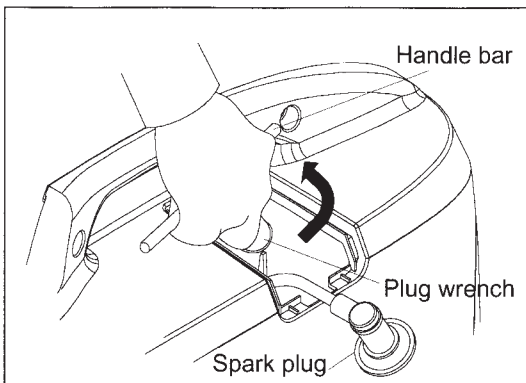

4.PRE-OPERATION CHECK



CAUTION

- Be sure to check the generator on a level surface with the engine stopped.

1. Check the engine oil level.



CAUTION

- Using nondetergent oil or 2-stroke engine oil could shorten the engine's service life.

Use high-detergent, premium quality 4-stroke engine oil, certified to meet or exceed U.S.automobile manufacturer's requirements for API Service Classification SG,SF.

Select the appropriate viscosity for the average temperature in your area.

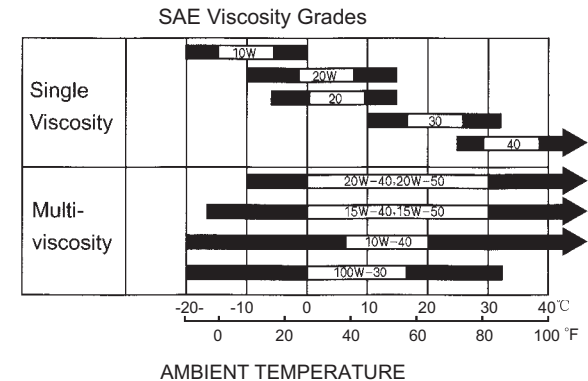

Loosen the cover screw and remove the left side maintenance cover. Remove the oil filler cap, and wipe the dipstick with a clean rag. Check the oil level by inserting the dipstick in the filler hole without screwing it in.

If the oil level is below the end of the dipstick, refill the recommended oil up to the top of the oil filler neck.



NOTE

- Running the engine with insufficient oil can cause serious engine damage.

NOTE: The Low Oil Alarm System will automatically stop the engine before the oil level falls below the safe limit. However, to avoid the inconvenience of an unexpected shutdown, it is still advisable to visually inspect the oil level regularly.

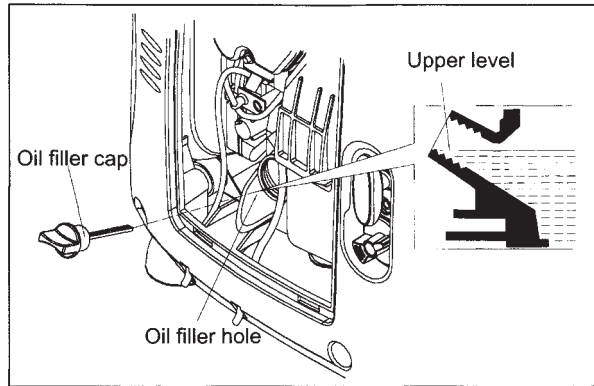

2. Check the fuel level.

Use automotive gasoline (Unleaded or lowleaded is preferred to minimize combustion chamber deposits).

If the fuel level is low, refuel the fuel tank until the level as specified.

Never use an oil/gasoline mixture or dirty gasoline.

Avoid getting dirt, dust or water in the fuel tank.

After refueling, tighten the fuel filler cap securely.

WARNING

- Gasoline is extremely flammable and is explosive under certain conditions.
- Refuel in a well-ventilated area with the engine stopped. Do not smoke or allow flames or sparks in the area where the engine is refueled or where gasoline is stored.
- Do not overfill the fuel tank (there should be no fuel above the upper limit mark). After refueling, make sure the tank cap is closed properly and securely.
- Be careful not to spill fuel when refueling. Spilled fuel or fuel vapor may ignite, if any fuel is spilled, make sure the area is dry before starting the engine.
- Avoid repeated or prolonged contact with skin or breathing of vapor, KEEP OUT OF REACH OF CHILDREN.

Wash your hands with soap and water after handling used oil.

NOTE

- Please dispose of used motor oil in a manner that is compatible with the environment. We suggest you take it in a sealed container to your local service station for reclamation. Do not throw it in the trash or pour it on the ground.

2. AIR CLEANER SERVICE

A dirty air cleaner will restrict air flow to the carburetor. To prevent carburetor malfunction, service the air cleaner regularly. Service more frequently when operating the generator in extremely dusty areas.

WARNING

- Do not use gasoline or low flash point solvents for cleaning. They are flammable and explosive under certain conditions.

1. Loosen the cover screw and remove the left side maintenance cover.
2. Press the latch tab on the top of the air cleaner body, and remove the air cleaner cover.
3. Wash the element in a non-flammable or high flash point solvent and dry it thoroughly.
4. Soak the element in clean engine oil and squeeze out the excess oil.
5. Reinstall the air cleaner element and the cover.
6. Reinstall the air cleaner cover by inserting the lower tabs, and the latch tab.
7. Reinstall the left side maintenance cover and tighten the cover screw securely.

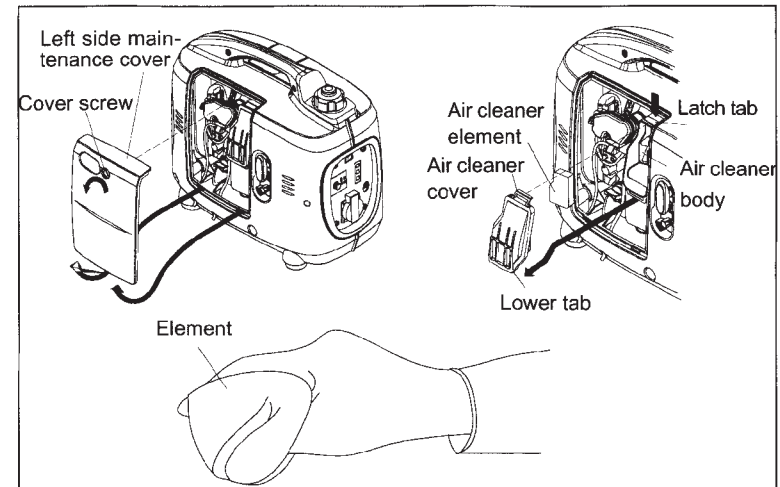

1.CHANGING OIL

Drain the oil while the engine is still warm to assure rapid and complete draining.



■ Make sure to turn the engine switch and the fuel cap lever OFF before draining.

- 1.Loosen the cover screw and remove the left side maintenance cover.
- 2.Remove the oil filler cap.
- 3.Drain dirty oil into a container thoroughly.
- 4.Refill with the recommended oil, and check the oil level.
- 5.Reinstall the left side maintenance cover and tighten the cover screw securely.

Engine oil capacity:0.25L

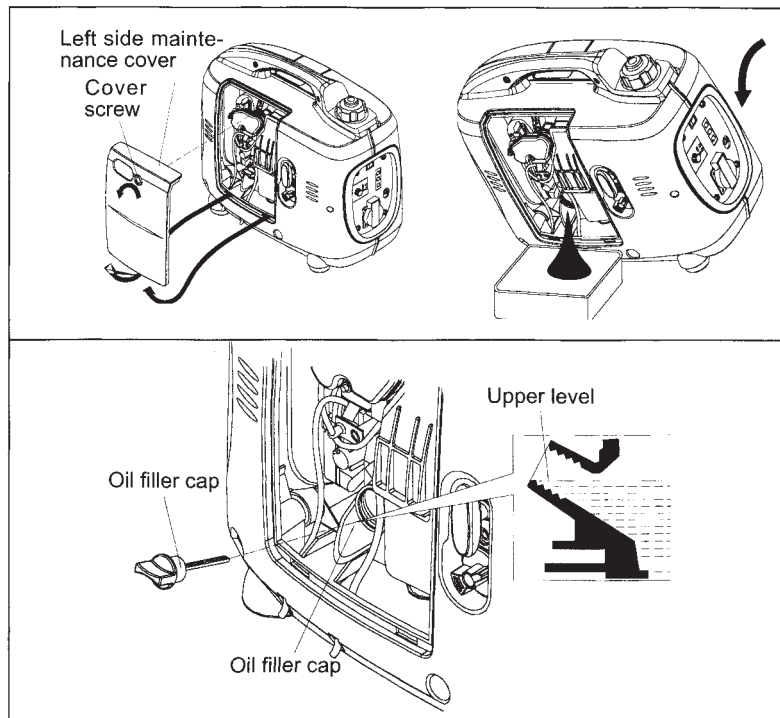

3.Check the air cleaner.

Check the air cleaner element to be sure it is clean and in good condition.

Loosen the cover screw and remove the left side maintenance cover. Press the latch tab on the top of the air cleaner body, remove the air cleaner cover, check the element. Clean or replace the element if necessary.

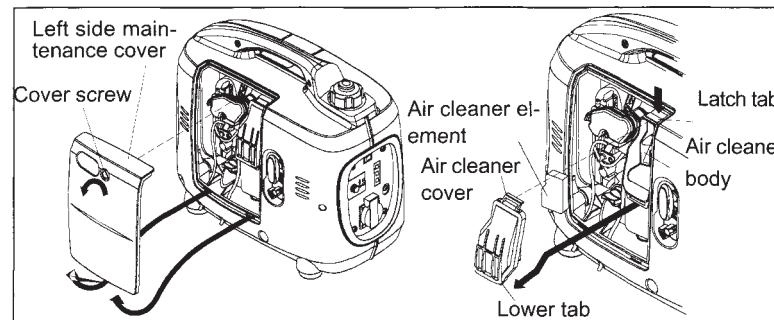

■ Never run the engine without the air cleaner. Rapid engine wear will result from contaminants, such as dust and dirt, being drawn through the carburetor, into the engine.

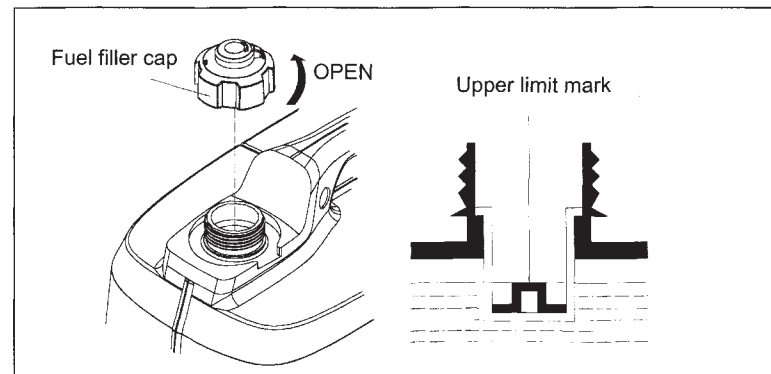

■ Turn the fuel cap lever to "OFF" position before transporting

5.STARTING THE ENGINE

Before starting the engine, disconnect the load from the DC terminals.

1.Turn the fuel cap lever fully clockwise to the ON position.

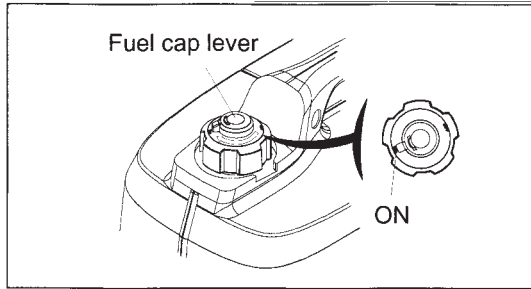

2.Turn the engine switch to the ON position.

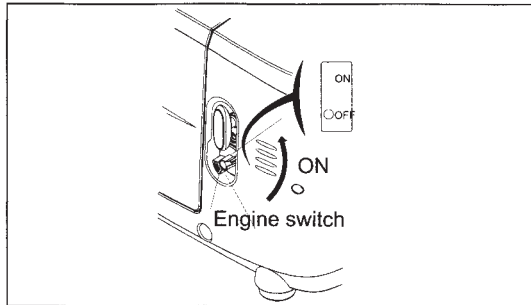

3.Move the choke lever to the START position.

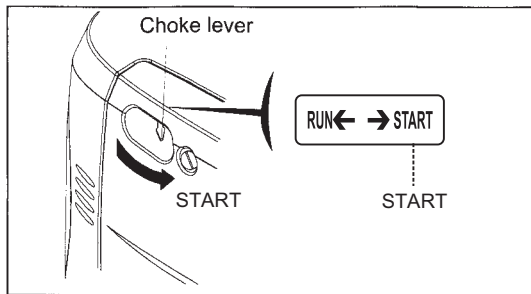

8.MAINTENANCE

The purpose of the maintenance and adjustment schedule is to keep the generator in the best operating condition.



WARNING

- Shut off the engine before performing any maintenance. If the engine must be run, make sure the area is well ventilated. The exhaust contains poisonous carbon monoxide gas.



CAUTION

- Use genuine our parts or their equivalent. The use of replacement parts which are not of equivalent quality may damage the generator.

Maintenance Schedule

REGULAR SERVICE PERIOD (1) Perform at every indicated month or operating hour interval, whichever occurs first.		EACH USE	FIRST MONTH OR 10HRS	EVERY 3 MONTHS OR 50HRS	EVERY 6 MONTHS OR 100 HRS	EVERY YEAR OR 300 HRS
ITEM						
Engine oil	Check	○				
	Change		○		○	
Air cleaner	Check	○				
	Clean			○ (2)		
Spark plug	Clean-adjust				○	
Spark arrester	Clean				○	
Fuel sediment cup					○	
Valve clearance	Check-adjust					○ (3)
Fuel tank and strainer	Clean					○ (3)
Fuel line	Check	Every 2 years (Replace if necessary)(3)				

NOTE: (1) Log hours of operation to determine proper maintenance.

(2) Service more frequently when used in dusty areas.

(3)These items should be serviced by an authorized dealer, unless the owner has the proper tools and is mechanically proficient. See the shop Manual.

3. Turn the cap lever fully counterclockwise to the "OFF" position.

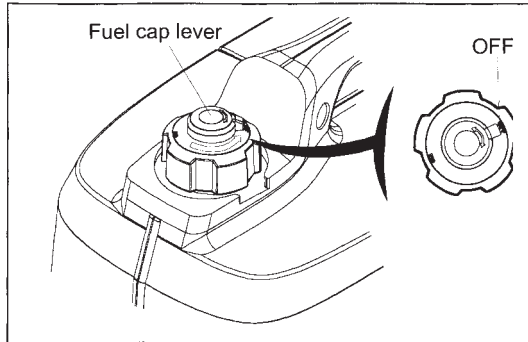

CAUTION ■ Be sure the fuel cap lever, choke and the engine switch are "OFF" when stopping, transporting and/or storing the generator.

NOTE

■ Do not use the choke when the engine is warm or the air temperature is high.

4. Pull the starter grip until resistance is felt, then pull the starter grip briskly toward the arrow as shown below.

CAUTION

■ Do not allow the starter grip to snap back, return it slowly by hand.

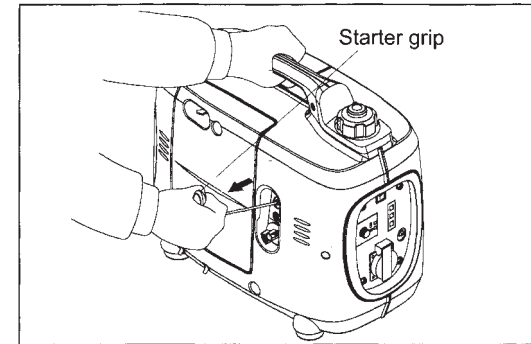

5. Move the choke lever to the RUN position after the engine warms up.

NOTE

■ If the engine stops and will not restart, check the engine oil level before troubleshooting in other areas.

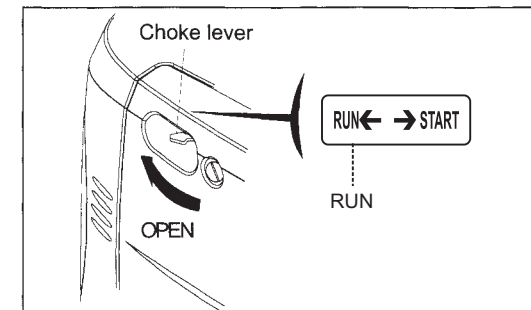

High altitude operation

At high altitude, the standard carburetor air-fuel mixture will be excessively rich. Performance will decrease, and fuel consumption will increase.

High altitude performance can be improved by installing a smaller diameter main fuel jet in the carburetor and readjusting the pilot screws. If you always operate the generator at altitudes higher than 1,500m (5,000 feet) above sea level, have your authorized dealer perform these carburetor modifications.

Even with suitable carburetor jetting, engine horsepower will decrease approximately 3.5% for each 305m (1,000 feet) increase in altitude. The affect of altitude on the horsepower will be greater than this if no carburetor modification is made.

CAUTION

- Operation of the generator at an altitude lower than the carburetor is jetted for may result in reduced performance, overheating, and serious engine damage caused by an excessively lean air/fuel

7.STOPPING THE ENGINE

To stop the engine in an emergency, turn the engine switch to the OFF position.

IN NORMAL USE:

- 1.Switch off the connected equipment and pull the inserted plug.

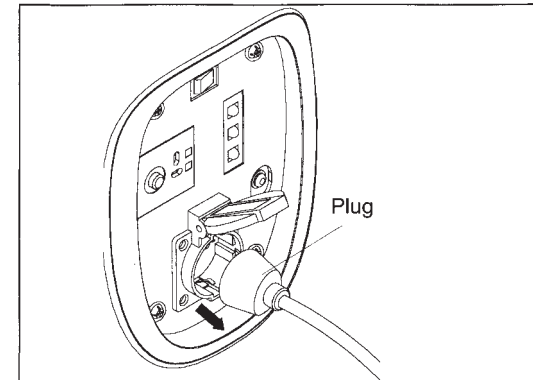

- 2.Turn the engine switch to the OFF position.

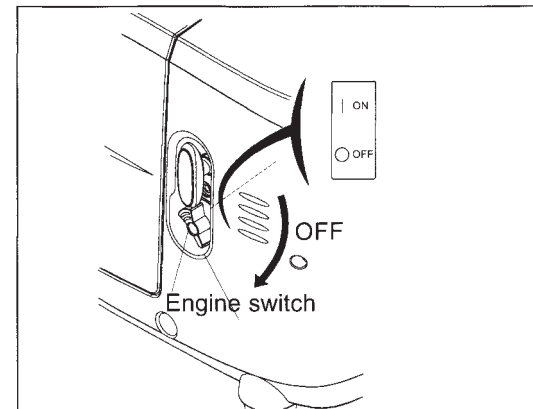

Low oil alarm system

The Low oil alarm system is designed to prevent engine damage caused by an insufficient amount of oil in the crankcase. Before the oil level in the crankcase falls below a safe limit, the Low oil alarm system will automatically shut down the engine (the engine switch will remain in the ON position).

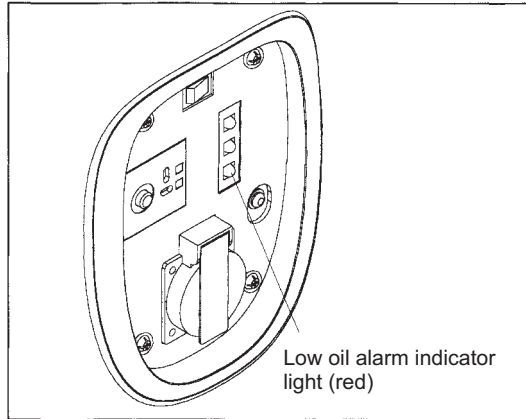

6.GENERATOR USE

⚠ WARNING

- To prevent electrical shock from faulty appliances, the generator should be grounded. Connect a length of heavy wire between the generator's ground terminal and an external ground source.
- Connections for standby power to a building's electrical system must be made by a qualified electrician and must comply with all applicable laws and electrical codes. Improper connections can allow electrical current from the generator to backfeed into the utility lines. Such backfeed may electrocute utility company workers or others who contact the lines during a power outage, and when utility power is restored, the generator may explode, burn, or cause fires in the building's electrical system.

⚠ CAUTION

- Limit operation requiring maximum power to 30 minutes. For continuous operation, do not exceed the rated power. In either case, the total wattage of all appliances connected must be considered.
- Do not exceed the current limit specified for any one receptacle.
- Do not connect the generator to a household circuit. This could cause the damage to the generator or to electrical appliances in the house.
- Do not modify or use the generator for other purposes than it is intended for. Also observe the following when using the generator.
 - Do not connect generators in parallel.
 - Do not connect an extension to the exhaust pipe.
- When an extension cable is required, be sure to use a tough rubber sheathed flexible cable.
- Limit length of extension cables; 60 m for cables if 1.5mm² and 100m for cables of 2.5 mm².
- Keep the generator away from other electric cables or wires such as commercial power supply lines.

NOTE

- The DC receptacle can be used while the AC power is in use. If you use both at the same time, be sure not to exceed the total power for AC and DC.
- Most appliance motors require more than their rated watt-age for start-up.

AC applications

- 1.Start the engine and make sure the output indicator light (green) comes on.
- 2.Confirm that the appliance to be used is switched off, and plug in the appliance.

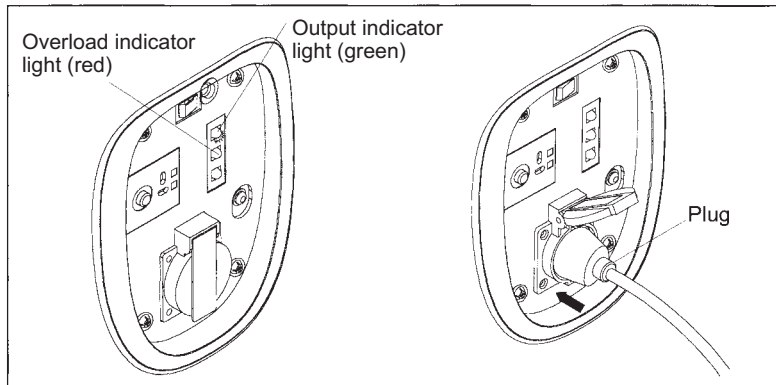

CAUTION

- Substantial overloading that continuously lights the overload indicator light (red) may damage the generator. Marginal overloading that temporarily lights the overload indicator light (red) may shorten the service life of the generator.
- Be sure that all appliances are in good working order before connecting them to the generator. If an appliance begins to operate abnormally, becomes sluggish, or stops suddenly, turn off the generator engine switch immediately. Then disconnect the appliance, and examine it for signs of malfunction.

WARNING

- The battery gives off explosive gases; keep sparks, flames and cigarettes away. Provide adequate ventilation when charging.
- The battery contains sulfuric acid (electrolyte). Contact with skin or eyes may cause severe burns. Wear protective clothing and a face shield.
 - If electrolyte gets on your skin, flush with water.
 - If electrolyte gets in your eyes, flush with water for at least 15 minutes and call a physician.
- Electrolyte is poisonous.
 - If swallowed, drink large quantities of water or milk and follow with milk of magnesia or vegetable oil and call a physician.
- KEEP OUT OF REACH OF CHILDREN.

2.Start the engine.

- The DC receptacle may be used while the AC power is in use.
 - An overload DC circuit will trip the DC circuit protector. If this happens, wait a few minutes before pushing in the circuit protector to resume operation.
- In order to acquire both the best effect and the maximum service life of the generator, usually, the new generator should run 20 hours under 50% load, the generator may reach the best performance.

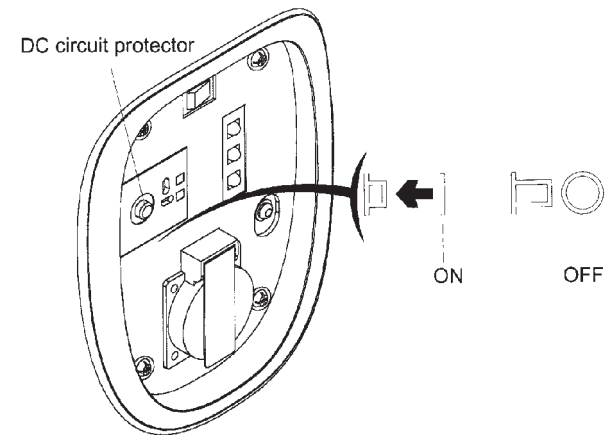

The DC receptacle may be used for charging 12 volt automotive-type batteries only, the zero load voltage is 15V-30V.

NOTE

- In DC operation, turn the Smart throttle switch to the OFF position.

1.Connect the charging cables to the DC receptacle of the generator and then to the battery terminals.

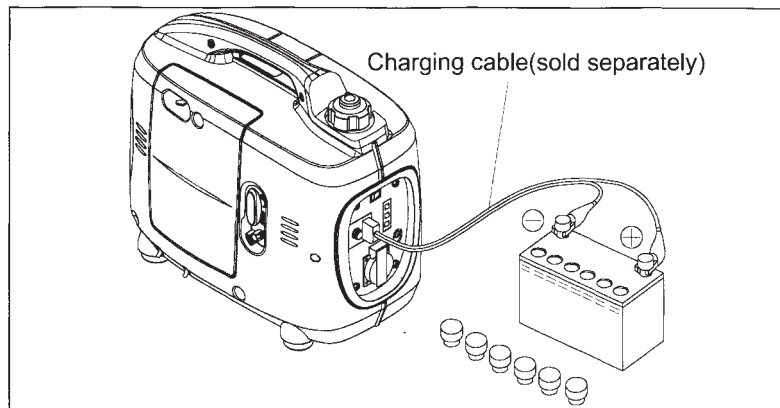

WARNING

- To prevent the possibility of creating a spark near the battery, connect charging cable first to the generator, then to the battery. Disconnect cable first at the battery.
- Before connecting charging cables to a battery that is installed in a vehicle, disconnect the vehicles grounded battery cable. Reconnect the vehicle's grounded battery cable after the charging cables are removed. This procedure will prevent the possibility of a short circuit and sparks if you make accidental contact between a battery terminal and the vehicle's frame or body.

CAUTION

- Do not attempt to start an automobile engine with the generator still connected to the battery. The generator may be damaged.
- Connect the positive battery terminal to the positive charging cord. Do not reverse the charging cables, or serious damage to the generator and/or battery may occur.

Output and Overload Indicators

The output indicator light(green)will remain ON during normal operating conditions.

If the generator is overloaded(in excess of 1.0kVA), or if there is a short in the connected appliance, the output indicator light(green) will go OFF, the overload indicator light(red) will go ON and current to the connected appliance will be shut off.

Stop the engine if the overload indicator light (red) comes ON and investigate the overload source.

- Before connecting an appliance to the generator, check that it is in good order, and that its electrical rating does not exceed that of the generator. Then connect the power cord of the appliance, and start the engine.

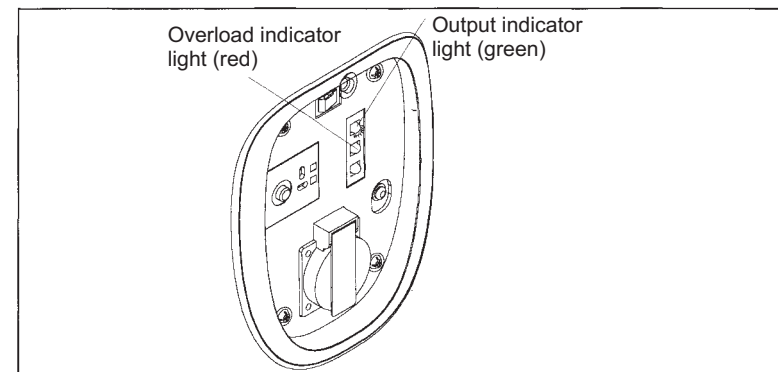

NOTE

- When an electric motor is started, both the overload indicator light(red) and the output indicator light (green) may go on simultaneously. This is normal if the overload indicator light(red) goes off after about four (4) seconds. If the overload indicator light (red) stays on, consult your generator dealer.

1. Connect the ground terminal.

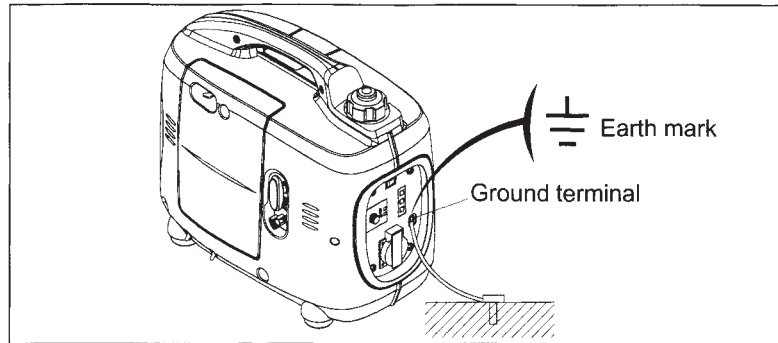

2. Start each engine according to "STARTING THE ENGINE".

When the output indicator light(green) does not light and the overload indicator light (red) lights instead, set the engine switch to STOP, stop the engine at once and then start the engine again.

3. Confirm that the equipment to be used is switched off, and insert the plug of the equipment to be used into the AC receptacle of unit A or unit B.

CAUTION

- Confirm that the use equipment to be connected is switched off.
- When the equipment to be used is switched on, it will operate suddenly, and injuries or accidents may be caused.

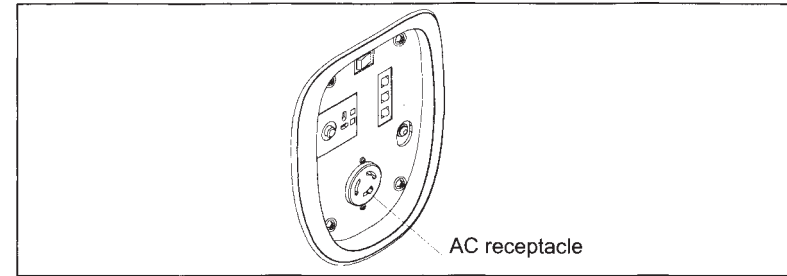
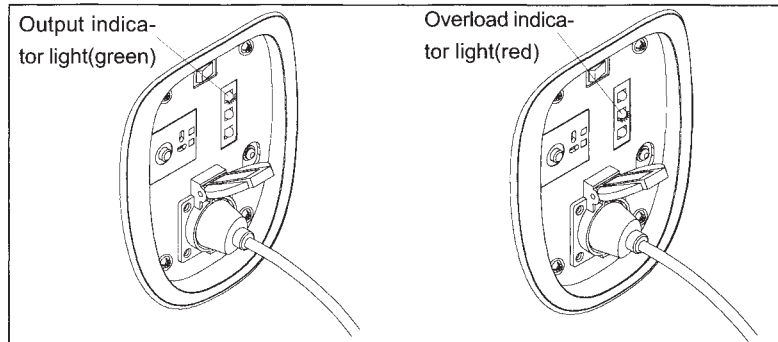

4. Switch on the equipment to be used.

In case of overload operation or when trouble occurs for the equipment being used, the output indicator light(green) will go out, the overload indicator light(red) will light continuously, and no power will be put out.

At this time, the engine will not stop, so that the engine must be stopped by setting the respective engine switch to STOP.

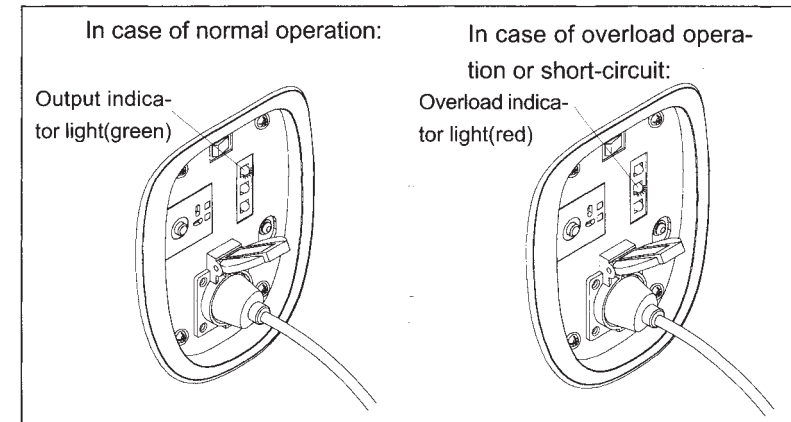

CAUTION

- When equipment requiring a large starting power, like a motor etc., is used, the overload indicator light (red) and the output indicator light(green) may light together for a short time (about 4 sec), but this is no abnormality. After start of the equipment, the overload indicator light (red) will go out and the output indicator light(green) will stay lit.